

**BAADER 1190  
Carcass Care®  
Picker**

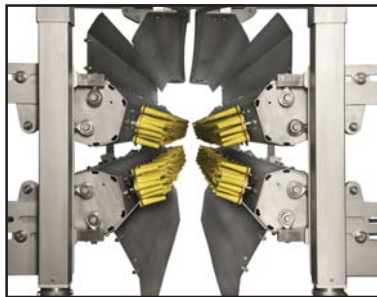

Picking capabilities include the following:

- Low maintenance - no lubrication required
- Easy to replace drive belt
- Low horsepower requirements
- Soft - start eliminates mechanical shock load
- Banks flexible for all picking positions (Primary to Finishing)
- Quick change off-the-shelf motors
- One person adjustment of banks
- Integrated feather guards and shackle guides
- Large work space for fingering



*Easily Adjustable Picking Banks*



*Easy Access For Maintenance*



*Quick Change Belt Drive*

**BAADER 1190-4**

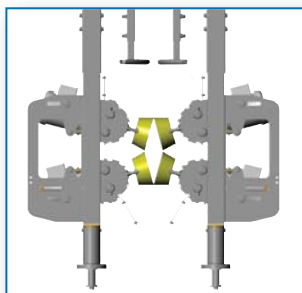

*Great for any position or bird size*

**BAADER 1190-5**

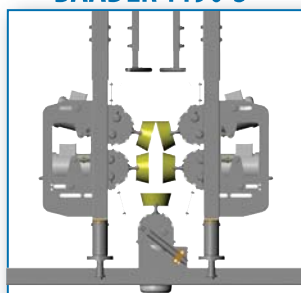

*The perfect finisher*

**BAADER 1190-6**

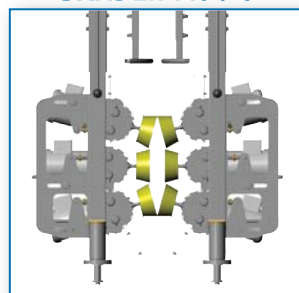

*The perfect fit for bigger birds*

**4-Bank, 5-Bank and 6-Bank Options**



# BAADER 1190 Carcass Care® Picker

## • Technical Data

<b>Operating Range</b>	US	Metric
	Min 3 Lb	1.4Kg
	Max 8 Lb	3.6Kg

Note: The indicated limits of the working ranges may vary as a function of the proportion, quality and nutritional condition of the bird. In order to achieve an optimal result, the machine should be adjusted within its working range to the bird size principally processed.

<b>Capacity</b>	Min 42 bpm (2,500bph)
	Max 160 bpm (9,600bph)

Note: All others subject to approval by Baader-Johnson

### Weights, Dimensions and Volume

<i>Machine Weight:</i>	6200 Lb	2800 Kg
<i>Shipping Weight:</i>	7300 Lb	3300 Kg
<i>Shipping Dims:</i>	L 180"	4600 mm
	W 64"	1700 mm
	H 55"	1400 mm
<i>Shipping Volume:</i>	367 ft3	10 m3
<b>Water</b>		
<i>Process Water Reqs:</i>	V 16 GPM	61 L/min
	P 40 PSI	3 bar
	T 100°F	38°C
<i>Process Water Connection:</i>	3/4" FNPT	3/4" FNPT

### Electrical

<i>Std. Elect. Requirements:</i> <small>(Per Elect. Motor Req't.)</small>	V 230/460V	230/400V
	Ph 3 Ph	3 Ph
	Hz 60 Hz	50 Hz
	HP 2 Hp	1.5 Kw

Note: All others subject to approval by Baader-Johnson

### Mechanical

<i>Shackle Length:</i>	Min 26"	661 mm
	Max 34"	864 mm
<i>Track Height Min</i>	Min 84"	2134 mm
	Max 115"	2921 mm
<i>Shackle Types:</i>	Stainless Steel Rigid Picking Shackle with Dragback Connection	

Note: All others subject to approval by Baader-Johnson

Note: All rigid shackles to be mounted with neutral clips or clips pointing away from the machine.

<i>Track Types:</i>	T-rail (50mm)
	I-Beam (3")
	Round Pipe Sch 80 42 x 5 mm

Note: All others subject to approval by Baader-Johnson

<i>Chain Types:</i>	Log chain (1")
	Log chain (1-1/2")
	X 348

Note: All others subject to approval by Baader-Johnson

Note: Chain stretch not to exceed 4%

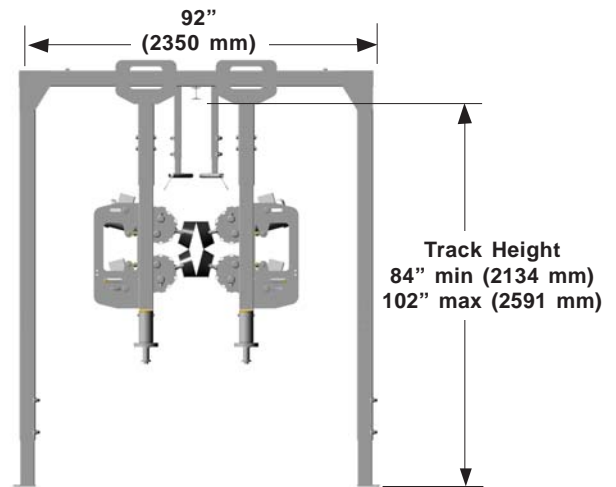
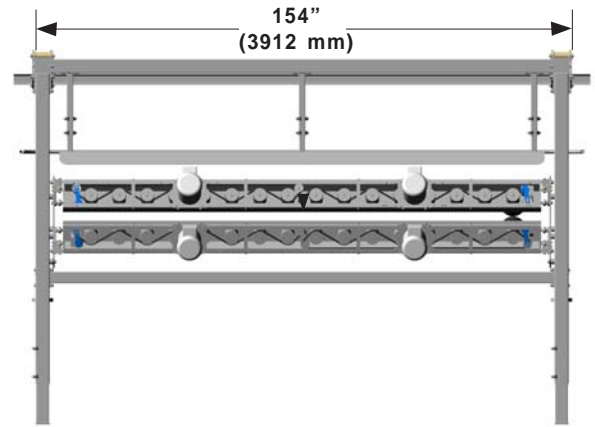

### Finger Information

10 Fingers Per Disc  
16 Picking Discs Per Bank

Illustrations and dimensions are approximate and not binding. Subject to design changes in the interest of technical progress. Actual scope of supply is specified in our quotations and order confirmations and may differ from descriptions and photos in this leaflet.

### Attention!

For the illustration of technical details the safety devices and protection mechanisms are partly not shown in operative condition. When operating the machine, all corresponding devices and instructions referring to the safety of the machine must be utilized and/or observed. (Protective panels and safety guards removed for photograph)



Johnson Food Equipment, Inc.  
Member of the BAADER Group  
2955 Fairfax Trafficway Kansas City, KS 66115  
Tel: 913-621-3366 Fax: 913-621-1729  
Email: [sales@baader-johnson.com](mailto:sales@baader-johnson.com)  
Web Site: [www.baader-johnson.com](http://www.baader-johnson.com)  
800-288-3434 U.S. & Canada