

## BAADER 1230 Carcass Care® Auto-Transfer Machine

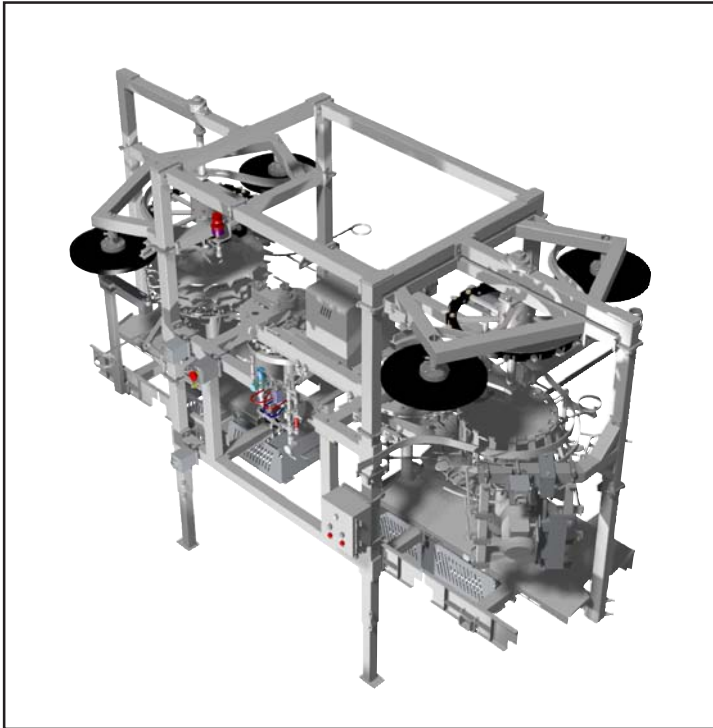

The Baader-Johnson Transfer Machine has the capability to automatically transfer one defeathering line to one or two evisceration lines (two machines required.)

Other features include:

- Compact Foot Print
- Low Maintenance Costs
- Simple, Durable and Effective Design.
- Compatible with two-part shackle and U.S straight shackle
- All line speeds

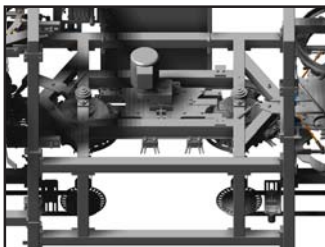

Buffer



Hock Cutting Station

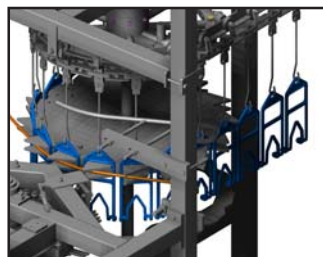

Re-Hang Station with  
Plastic Shackles



# BAADER 1230 Carcass Care® Auto-Transfer Machine

## • Technical Data

<b>Operating Range</b>	US	Metric
	Min 3 Lb	1.4Kg
	Max 8 Lb	3.6Kg

Note: The indicated limits of the working ranges may vary as a function of the proportion, quality and nutritional condition of the bird. In order to achieve an optimal result, the machine should be adjusted within its working range to the bird size principally processed.

<b>Capacity</b>	Min 42 bpm (2,500bph)
	Max 160 bpm (9,600bph)

Note: All others subject to approval by Baader-Johnson  
180 bpm (10,800 bph) for 1:1  
230 bpm (9,600bph) for 2:1

### Weights, Dimensions and Volume

<b>Machine Weight:</b>	4000 Lb	1800 Kg
<b>Shipping Weight:</b>	4500 Lb	2050 Kg
<b>Shipping Dims:</b>	L 168"	4300 mm
	W 60"	1600 mm
	H 110"	2800 mm
<b>Shipping Volume:</b>	642ft <sup>3</sup>	18m <sup>3</sup>

### Water

<b>Process Water Reqs:</b>	V 10 GPM	38 L/min
	P 40 PSI	3 bar
	T 60°F	16°C
<b>Process Water Connection:</b>	1/2" FNPT	1/2" FNPT

### Air

<b>Air Requirements:</b>	V 1 CFM	17 m <sup>3</sup> /hr
	P 60 PSI	3 bar
<b>Air Dew Point:</b>	32°F	0°C
<b>Air Connection:</b>	1/2" FNPT	1/2" FNPT

### Electrical

<b>Std. Elect. Requirements:</b>	V 230/460V	230/460V
	Ph 3 Ph	3 Ph
	Hz 60 Hz	60 Hz
	Amp 10/20 A	10/20 A

Note: All others subject to approval by Baader-Johnson

### Mechanical

<b>Torque Requirements:</b>	150 ft lb	205 Nm - Picking Side
	100 ft lb	140 Nm - Evis. Side
<b>Shackle Length:</b>	Min 26"	661 mm
	Max 34"	864 mm
<b>Track Height Min</b>	Min 100"	2540 mm
	Max 115"	2921 mm

**Shackle Types:** All common rigid picking shackles - Picking Side  
Plastic BJ rigid shackle - Evis Side  
Plastic & Stainless BJ 2-piece - Evis Side

Note: All others subject to approval by Baader-Johnson

Note: All rigid shackles to be mounted with neutral clips or clips pointing away from the machine.

<b>Track Types:</b>	T-rail (50 mm)
	I-Beam (3")
	Round Pipe Sch 80 42 x 5 mm

Note: All others subject to approval by Baader-Johnson

<b>Chain Types:</b>	Log chain (1")
	Log chain (1-1/2")
	X 348

Note: All others subject to approval by Baader-Johnson

Note: Chain stretch not to exceed 4%

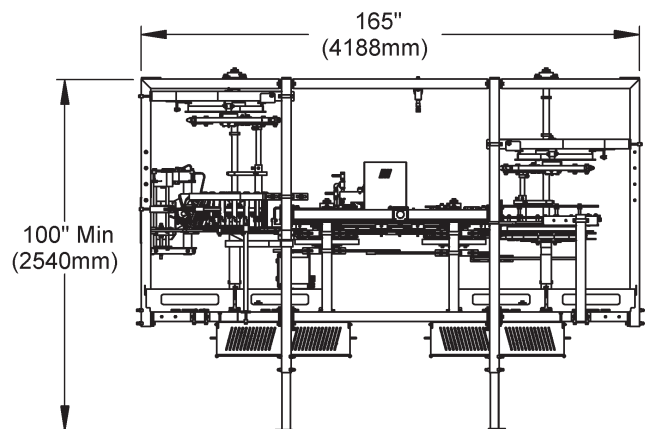
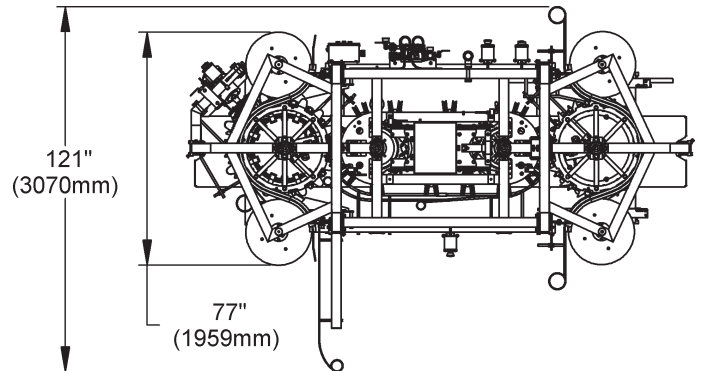

Illustrations and dimensions are approximate and not binding. Subject to design changes in the interest of technical progress. Actual scope of supply is specified in our quotations and order confirmations and may differ from descriptions and photos in this leaflet.

#### Attention!

For the illustration of technical details the safety devices and protection mechanisms are partly not shown in operative condition. When operating the machine, all corresponding devices and instructions referring to the safety of the machine must be utilized and/or observed. (Protective panels and safety guards removed for photograph)



Johnson Food Equipment, Inc.  
Member of the BAADER Group  
2955 Fairfax Trafficway Kansas City, KS 66115  
Tel: 913-621-3366 Fax: 913-621-1729  
Email: [sales@baader-johnson.com](mailto:sales@baader-johnson.com)  
Web Site: [www.baader-johnson.com](http://www.baader-johnson.com)  
800-288-3434 U.S. & Canada