

Simply the
Best Carcass
Washer
Available!

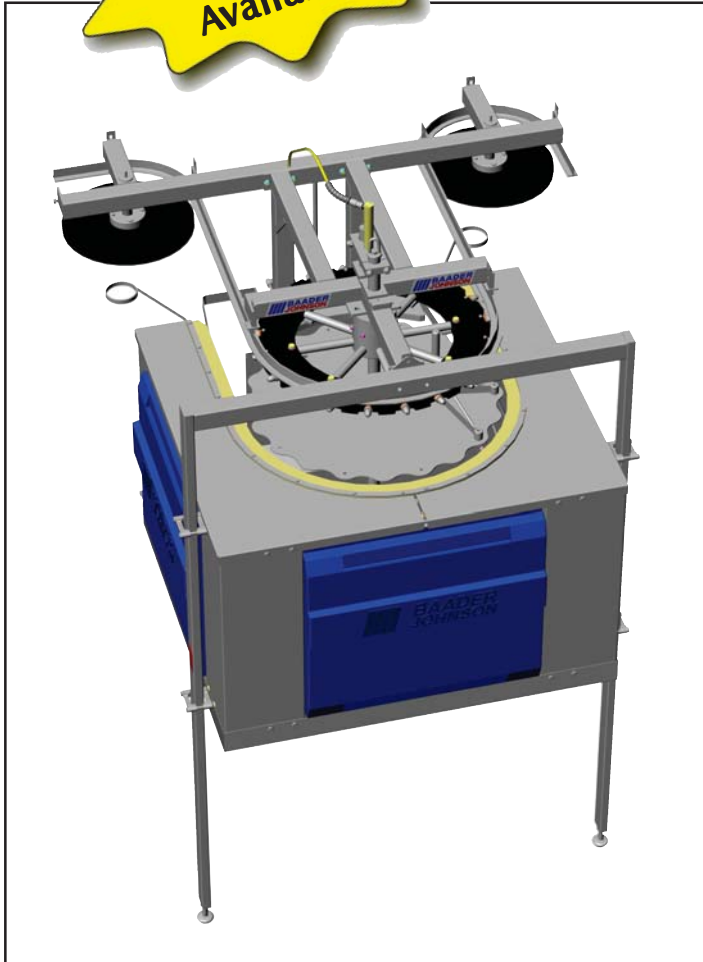

BAADER 1497 Carcass Care® Carcass Washer

- Tilting cradle and head operation results in thorough flushing through abdominal and neck openings as well as leaf fat areas.
- Multiple sprays at critical areas ensure complete washing of product inside and out.
- Full cabinet enclosure for containment of over spray and easy cleaning
- High flow shaft, nozzle and manifold assembly
- USDA Approved

Simple, Durable and Effective
**CARCASS
BAADER
CARE®**



BAADER 1497 Carcass Washer

• Technical Data

Operating Range	US	Metric
	Min 3 Lb	1.4 Kg
	Max 8 Lb	3.6 Kg

Note: The indicated limits of the working ranges may vary as a function of the proportion, quality and nutritional condition of the bird. In order to achieve an optimal result, the machine should be adjusted within its working range to the bird size principally processed.

Capacity	Min 42 bpm (2,500 bph)
	Max 160 bpm (9,600 bph)

Note: All others subject to approval by Baader-Johnson

Machine Options

20 Heads, 6" On Center-Up to 160 BPM
15 Heads, 8" On Center-Up to 120 BPM

Weights, Dimensions and Volume

<i>Machine Weight:</i>	1020 Lb	450 Kg
<i>Shipping Weight:</i>	1200 Lb	550 Kg
<i>Shipping Dims:</i>	L 130"	3302 mm
	W 80"	2032 mm
	H 80"	2032 mm
<i>Shipping Volume:</i>	481 ft ³	14 m ³

Water

<i>Process Water Reqs:</i>	V	60 GPM	227 L/min
		80 GPM	303 L/min
		100 GPM	379 L/min
P		60 PSI	4 bar
		80 PSI	6 bar
		100 PSI	7 bar
	T	60°F	16°C
<i>Process Water Connection:</i>	1/2" FNPT	1/2" FNPT	

Mechanical

<i>Torque Requirements:</i>	60 ft/Lb	100 Nm
<i>Shackle Length:</i>	Min 26"	661 mm
	Max 34"	864 mm
<i>Track Height Min</i>	Min 84"	2134 mm
	Max 115"	2921 mm
<i>Shackle Types:</i>	Plastic BJ rigid shackle Plastic & Stainless BJ 2-piece	

Note: All others subject to approval by Baader-Johnson

Note: All rigid shackles to be mounted with neutral clips or clips pointing away from the machine.

<i>Track Types:</i>	T-rail (50mm)
	I-Beam (3")
	Round Pipe Sch 80 42 x 5mm

Note: All others subject to approval by Baader-Johnson

<i>Chain Types:</i>	Log chain (1")
	Log chain (1-1/2")
	X 348

Note: All others subject to approval by Baader-Johnson

Note: Chain stretch not to exceed 4%

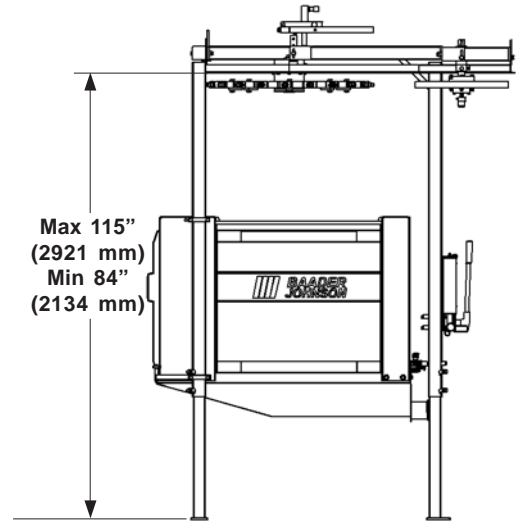
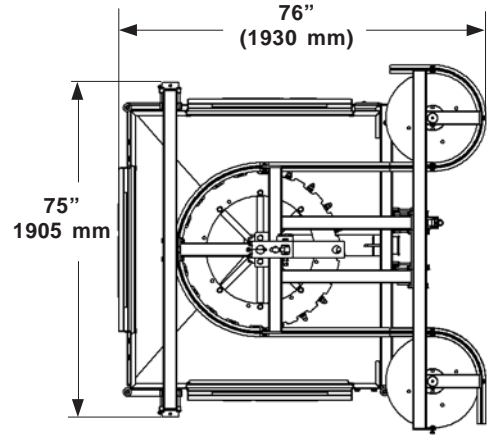

Illustrations and dimensions are approximate and not binding. Subject to design changes in the interest of technical progress. Actual scope of supply is specified in our quotations and order confirmations and may differ from descriptions and photos in this leaflet.

Attention!

For the illustration of technical details the safety devices and protection mechanisms are partly not shown in operative condition. When operating the machine, all corresponding devices and instructions referring to the safety of the machine must be utilized and/or observed. (Protective panels and safety guards removed for photograph)



Johnson Food Equipment, Inc.
Member of the BAADER Group
2955 Fairfax Trafficway Kansas City, KS 66115
Tel: 913-621-3366 Fax: 913-621-1729
Email: sales@baader-johnson.com
Web Site: www.baader-johnson.com
800-288-3434 U.S. & Canada