

**BAADER 1701  
Head Puller**

- Removes heads on picking lines
- Some wind pipes and crops removed with head depending on style of kill
- Non-clogging top surface
- Floor or track mounting
- Easy adjustment
- Small footprint
- Stainless steel construction
- Simple and durable



## BAADER 1701 Head Puller

### • Technical Data

#### **Function**

Removes heads on picking lines  
Some wind pipes and crops removed with  
head depending on style of kill.

#### **Capacity**

Up to and including 280 bph.

Note: All others subject to approval by Baader-Johnson

#### **Broiler Size Range**

Any size broiler.

#### **Materials of Construction**

All stainless steel.

#### **Weights, Dimensions and Volume**

<i>Machine Weight:</i>	200 lbs	91 kg
<i>Shipping Weight:</i>	280 lbs	127 kg
<i>Crated Dims:</i>	61.8 ft <sup>3</sup>	1.75 m <sup>3</sup>

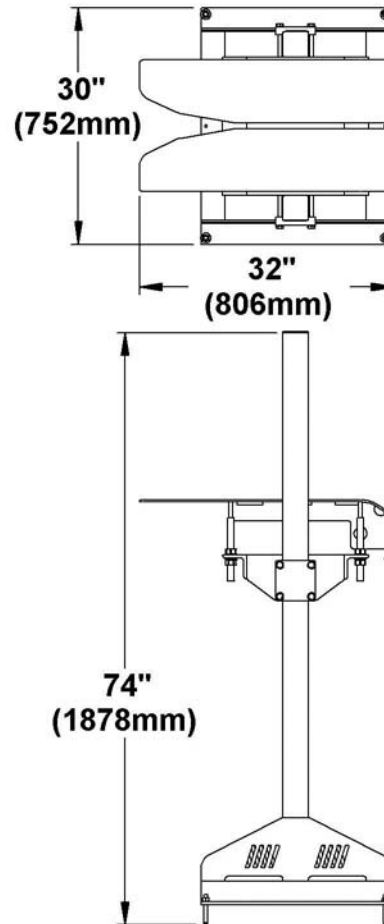

Illustrations and dimensions are approximate and not binding.  
Subject to design changes in the interest of technical progress.  
Actual scope of supply is specified in our quotations and order  
confirmations and may differ from descriptions and photos in this  
leaflet.

#### **Attention!**

For the illustration of technical details the safety devices and  
protection mechanisms are partly not shown in operative condi-  
tion. When operating the machine, all corresponding devices and  
instructions referring to the safety of the machine must be utilized  
and/or observed. (Protective panels and safety guards removed  
for photograph)

**BAADER  
JOHNSON**  
Food Processing Machinery

Johnson Food Equipment, Inc.  
Member of the BAADER Group  
2955 Fairfax Trafficway Kansas City, KS 66115  
Tel: 913-621-3366 Fax: 913-621-1729  
Email: [sales@baader-johnson.com](mailto:sales@baader-johnson.com)  
Web Site: [www.baader-johnson.com](http://www.baader-johnson.com)  
800-288-3434 U.S. & Canada