

BA601 Meat Separator

- Separates soft and solid components, providing highest yield and superior product quality
- Separation is attained by means of a gentle pressure system:
 - A squeezing belt feeds product to a perforated drum and presses the soft components through the holes
 - Solid components remain outside the drum
 - Raw product and hole diameter of drum determine texture of final product
 - Ratio between yield and quality can be varied by means of an adjustable roller
- Accepts a wide variety of products
- Space saving efficiency with only 1 operator
- Easy cleaning and maintenance

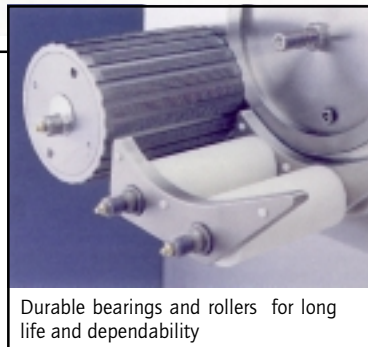

Durable bearings and rollers for long life and dependability



BA601 Soft Belt Meat Separator



■ Technical Data

■ Materials of Construction

Stainless steel, plastic

■ Available Drum Hole Diameters

1.3, 2, 3, 5, or 8 mm
Other diameters upon request

■ Shipping Weights and Measures

Net Weight: 385 kg (849 lbs)
Crated Weight: 435 kg (959 lbs)
Crated Dimensions: 1500 x 1100 x 1500 mm
(59 x 43 x 59 in)

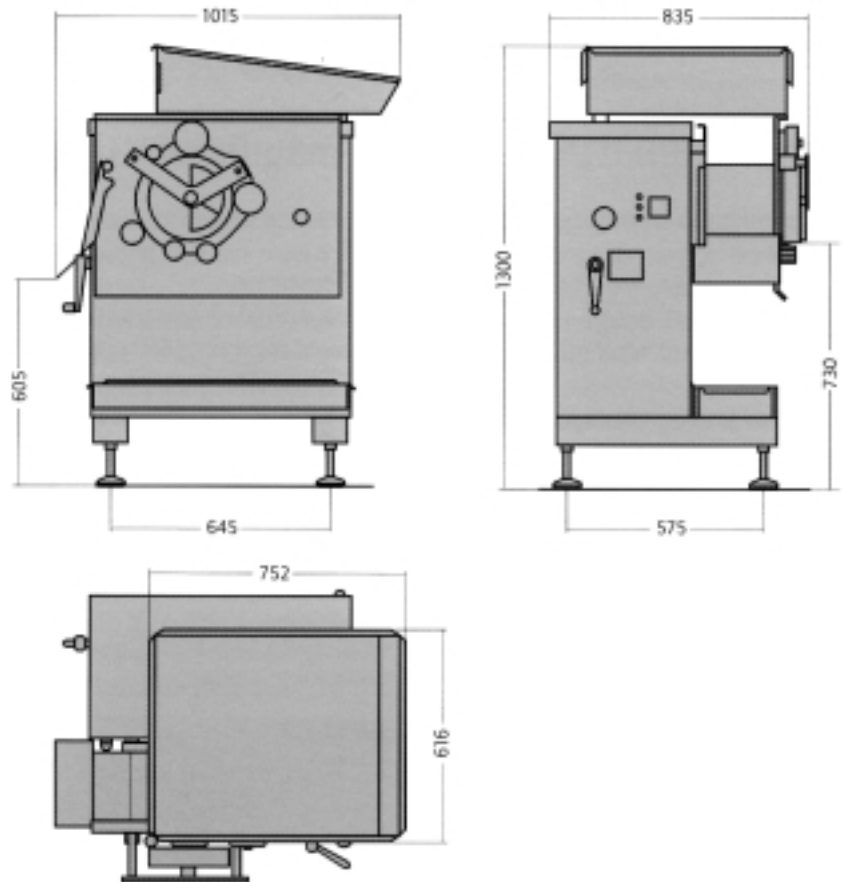

The specifications as stated herein are the most current at the time of publication. However, consistent with our standard of continual product improvement, we reserve the right to change the design without notice or obligation on our part to modify any equipment previously sold or delivered.

Johnson Food Equipment, Inc. Member of the BAADER Group

2955 Fairfax Trafficway
Kansas City, KS 66115

Tel: 913-621-3366

Fax: 913-621-1729

Email: sales@baader.johnson.com

Web Site: www.baader.johnson.com

800-288-3434

U.S. & Canada